



PHASER® 740 and 740L  
LASER PRINTERS  
User Guide



[www.tek.com/Color\\_Printers/](http://www.tek.com/Color_Printers/)



# Contents

Tektronix Supplies	1
Getting The Most From Your Printer	2
Printing	3
All About Media	4
Loading Media Trays	7
Using the Multi-Purpose Tray	8
Duplex Printing	16
Front Panel Messages	20
Troubleshooting Print Quality	21
Media Jams	26
Occasional Cleaning	32
Printing Help Pages from the Front Panel	33
Consumables	37
Controlling Color Density	38
Getting More Information	41
Getting Help	42

## Symbols

### Note



General information

### Caution



Use caution or damage to the printer may result.

### Hot



Hot surface on or in the printer. Use caution to avoid personal injury.

Copyright © 1998 by Tektronix, Inc. All rights reserved.  
Tektronix® and Phaser® are registered trademarks of Tektronix, Inc.

## Tektronix Supplies

Supplies	Order number	Description
<b>Toner Cartridges</b>	<b>Hi-Capacity</b>	<b>Standard</b>
		<b>Color</b>
	016-1656-00	016-1684-00 Black
	016-1657-00	016-1685-00 Cyan
	016-1658-00	016-1686-00 Magenta
	016-1659-00	016-1687-00 Yellow
<b>Fuser</b>	016-1660-00	110 volt
	016-1661-00	220 volt
<b>Fuser Roll</b>	016-1663-00	
<b>Imaging Unit</b>	016-1662-00	
<b>Transfer Kit</b>	016-1664-00	
<b>Main Charge Grid</b>	016-1665-00	
<b>Laser paper</b>		
A/Letter (U.S.)	016-1368-00	500 sheets
A4 (Metric Letter)	016-1369-00	500 sheets
<b>Glossy Coated paper</b>		
A/Letter (U.S.)	016-1704-00	100 sheets
A4 (Metric Letter)	016-1705-00	100 sheets
<b>Transparencies</b>		
A/Letter (U.S.)	016-1654-00	50 sheets
A4 (Metric Letter)	016-1655-00	50 sheets

Accessories	Order number	Description
<b>Paper Trays</b>	436-0282-02	A/Letter (U.S.)
	436-0283-02	A4 (Metric Letter)
	436-0314-02	Legal
<b>Transparency Trays</b>	436-0284-02	A/Letter (U.S.)
	436-0285-02	A4 (Metric Letter)
<b>Automatic Duplex / Lower Tray Assembly</b>	ZDPLX	Includes one each: Duplex Unit, Paper tray, and Transparency tray; order option 01 for Metric.
<b>Printer Cart</b>	ZCARTA	
<b>Cleaning Kit</b>	016-1710-00	
<b>Alcohol Cleaning Wipes</b>	006-7824-01	Pack of 10
<b>Printer CD-ROM</b>	063-3079-00	-00 English -70 Chinese, Simplified
<b>Printer Diskettes</b>	063-3078-00	-10 French -80 Chinese, Traditional
		-20 Italian -40 Spanish -90 Korean
		-30 German



To order supplies and accessories, contact your local dealer or visit the Tektronix web site:

[www.tek.com/Color\\_Printers/supplies](http://www.tek.com/Color_Printers/supplies)

## Getting The Most From Your Printer

<b>Supplies Startup Kit</b> Z740SS Option 01 for Metric	<ul style="list-style-type: none"> <li>■ 4 Standard color Toner Cartridges (CMYK)</li> <li>■ Glossy Coated Paper (100 sheets)</li> <li>■ Tektronix Transparencies (50 sheets)</li> </ul>
<b>Color Kit</b> Z740LCS	<p>Converts a Phaser 740L color-capable printer to a full-color printer:</p> <ul style="list-style-type: none"> <li>■ Adds three color toners.</li> <li>■ Converts the Phaser 740L product warranty from a 1-year return-to-depot <b>to a 1-year on-site</b> for the <b>remainder of the warranty period.</b></li> </ul>
<b>Automatic Duplex/ Lower Tray Assembly</b> ZDPLX Option 01 for Metric	<ul style="list-style-type: none"> <li>■ <b>Automatic</b> duplex with the Duplex Unit</li> <li>■ Lower Tray Assembly</li> <li>■ Increased paper-printing capacity</li> <li>■ Increased printing versatility and convenience</li> </ul>
<b>Plus Feature Set</b> Z740FP* * Includes installation	<ul style="list-style-type: none"> <li>■ 1200 dpi</li> <li>■ Premium print-quality mode</li> <li>■ Adds SCSI card for connecting an external hard drive or a copy unit</li> <li>■ Check Print and Quick Collate functionality</li> <li>■ Requires a minimum of 64 Mbytes of memory (must be purchased separately)</li> </ul>
<b>Scanner support</b> Requires Plus Features	<ul style="list-style-type: none"> <li>■ Use your printer as a color copier.</li> <li>■ For a list of supported scanners, contact your local Tektronix reseller, or visit the Tektronix web site.</li> </ul>

<b>External Hard Disk</b> ZDISK	<ul style="list-style-type: none"> <li>■ Required for collation</li> <li>■ Extends font capacity</li> <li>■ Requires Plus Feature set</li> </ul>
<b>PhaserShare<sup>®</sup> Network Card</b>  ZNBFE ZNBTR ZNBLT	<ul style="list-style-type: none"> <li>■ Easy to install</li> <li>■ Increases speed and shareability</li> <li>■ High-performance network connectivity</li> </ul> <p>100Base-T Ethernet</p> <p>Token Ring</p> <p>LocalTalk</p>
<b>PhaserLink<sup>™</sup> Software</b>  Requires network connection via TCP/IP	<ul style="list-style-type: none"> <li>■ View printer status using any web browser.</li> <li>■ Control printer settings.</li> <li>■ Link to online documentation via the World Wide Web.</li> <li>■ Receive electronic mail when consumables are low or other printer maintenance is required.</li> </ul>
<b>Additional memory</b>  ZMB32 ZMB64 ZMB128	<ul style="list-style-type: none"> <li>■ Improved performance</li> </ul> <p>32 Mbytes</p> <p>64 Mbytes</p> <p>128 Mbytes</p>

## Print Quality Modes

<b>Standard</b>	<ul style="list-style-type: none"><li>■ General-purpose mode for full-color printing.</li></ul>
<b>Premium Monochrome</b>	<ul style="list-style-type: none"><li>■ Highest-quality monochrome (gray scale) prints.</li></ul>
<b>Premium</b> Requires Plus Features	<ul style="list-style-type: none"><li>■ Highest-quality color prints.</li><li>■ Near-photographic detail.</li></ul>
<b>Fast Monochrome</b>	<ul style="list-style-type: none"><li>■ Fastest gray scale printing.</li><li>■ Recommended for documents with lots of black text.</li></ul>
<b>Fast Color</b>	<ul style="list-style-type: none"><li>■ Fastest full-color output.</li><li>■ Excellent output using CMY toners for raster image data or color graphics.</li></ul>
<b>Presentation</b>	<ul style="list-style-type: none"><li>■ Smoothest and brightest large-area fills.</li><li>■ Useful for printing paper copies of overhead presentations.</li></ul>

## TekColor™ Color Corrections

<b>Automatic</b>	<ul style="list-style-type: none"><li>■ Automatically applies the best color correction mode to each element on the page.</li></ul>
<b>SWOP</b>	<ul style="list-style-type: none"><li>■ Specification for Web Offset Publications. Used to match U.S. press standards.</li></ul>
<b>Euroscale</b>	<ul style="list-style-type: none"><li>■ Used to match equivalent Imation Matchprint® proofs.</li></ul>
<b>Commercial</b>	<ul style="list-style-type: none"><li>■ Used to match commercial Imation Matchprint® proofs.</li></ul>
<b>Toyo</b>	<ul style="list-style-type: none"><li>■ Used to match commercial Toyo printing inks on coated paper.</li></ul>
<b>DIC</b>	<ul style="list-style-type: none"><li>■ Used to match Dai Nippon printing inks on coated paper.</li></ul>
<b>None</b>	<ul style="list-style-type: none"><li>■ No color correction made to colors.</li><li>■ Used with the PANTONE® Color Chart for PANTONE® Color matching.</li></ul>
<b>Vivid Color</b>	<ul style="list-style-type: none"><li>■ Produces the brightest possible colors.</li></ul>
<b>sRGB Display</b>	<ul style="list-style-type: none"><li>■ Adjusts color to closely approximate the colors on a standard display screen.</li></ul>



To learn more about using color, visit our color web site:

[www.colorize.com](http://www.colorize.com)

## All About Media

### Paper Trays

#### Laser paper only

- Tray sizes:  
A/Letter A4 Legal
- 60 - 90 g/m<sup>2</sup>, 16 - 24 lb.
- 250-sheet capacity
- Use Tektronix media for best results

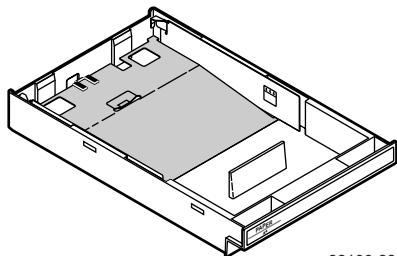

33100-38

### Transparency Tray

#### Tektronix transparencies only

- Tray sizes:  
A/Letter A4
- 100-sheet capacity
- Always use Tektronix transparencies for best results

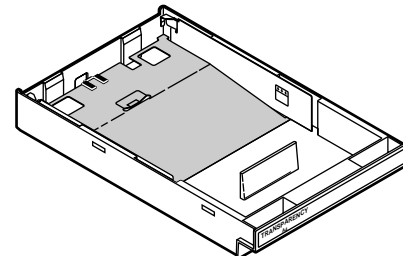

33100-20



*Load only laser paper in the paper trays; specialty media (such as glossy paper, card stock, envelopes, and labels) must be loaded in the Multi-Purpose Tray.*

## Multi-Purpose Tray

### Laser paper

- A/Letter A4 Legal
- 75 - 150 g/m<sup>2</sup>, 20 - 40 lb.

### Tektronix transparencies

- A/Letter A4

### Tektronix Glossy Coated paper

- A/Letter A4

### Laser labels

- A/Letter A4
- Recommended Avery™ labels  
(U.S.: 5160, 5164; Metric: L7162, L7165)

### Tektronix Fabric Transfer media

- A/Letter A4

### Envelopes

- #10

### Other media

- Cover stock up to 163 g/m<sup>2</sup>, 60 lb.
- Card stock up to 163 g/m<sup>2</sup>, 40 lb.
- Index up to 163 g/m<sup>2</sup>, 90 lb.

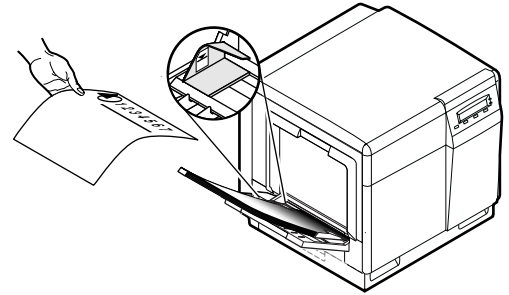

33100-21

### Media sizes supported in the Multi-Purpose Tray

**Metric:** 88.9 x 254 mm – 216 x 355.6 mm

**U.S.:** 3.5 x 10 in. – 8.5 x 14 in.

## Supported page sizes and image area

The printer supports four media sizes, which you select in the **Print** screen (using a supported printer driver).

Media	Page size	Print area	Margins	
			Top / Bottom	Sides
<b>1 Letter</b>	8.5 x 11 in.	8.2 x 10.6 in.	.2 in.	.15 in.
<b>2 A4</b>	210 x 297 mm	200 x 287 mm	5 mm	5 mm
<b>3 Legal</b>	8.5 x 14 in.	8.2 x 13.6 in.	.2 in.	.15 in.
<b>4 #10 Envelope</b>	4.13 x 9.5 in. (104.8 x 241.3 mm)	3.8 x 9.2 in. (96.5 x 233.7 mm)	.16 in. (4.1 mm)	.14 in. (3.6 mm)

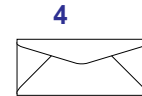
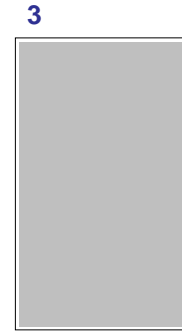
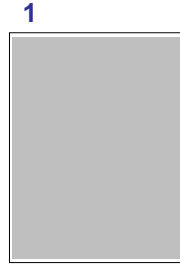



## Loading Media Trays

- 1 Push down on the tray's metal plate until it clicks, locking it in place.
- 2 Fan the media to release sheets that are stuck together.
- 3 Place the media in the tray under the hooks.

 Place the side to be printed (for example, letterhead paper) **face-down** under the hooks.

- 4 **Transparencies:** Place the Tektronix logo strip **face-up** under the hooks.
- 5 Tray capacity:

- Paper: 250 sheets
- Tektronix Transparencies: 100 sheets

 Keep the media level below the indicator on the tray's label; otherwise, the printer may jam.

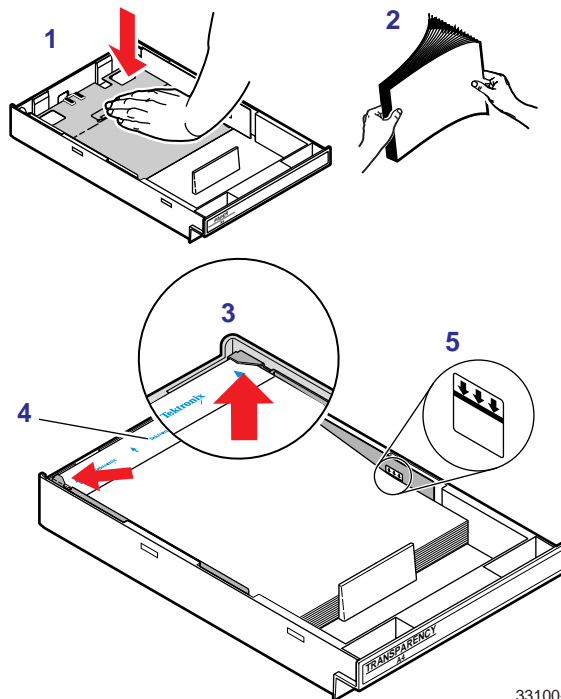

33100-48

## Using the Multi-Purpose Tray

- 1 Adjust the guides for the width of the media.
- 2 Adjust the **Media Thickness** switch for the media you are using (see page 9).
- 3 Insert the media, printing side **face-up** (for Tektronix transparencies, the logo strip is **face-down**).
- 4 Select the media type at the front panel:

<b>Paper</b>	■ Standard paper and letterhead 75 - 105 g/m <sup>2</sup> , 20 - 28 lb.
<b>Paper 2nd Side</b>	■ Duplex laser paper
<b>Transparency</b>	■ Tektronix transparencies
<b>Coated Paper</b>	■ Tektronix Glossy Coated paper
	■ Heavy paper 109 - 150 g/m <sup>2</sup> , 29 - 40 lb.
<b>Card or Envelope</b>	■ Card stock / Index ■ Cover stock ■ Envelope
<b>Label</b>	■ Laser labels
<b>Fabric Transfer</b>	■ Tektronix Fabric Transfer media



*The printer waits a minute for you to select the media type. After a minute, the job prints, using the previously selected media type.*

- 5 In the **Print** screen (using a supported driver), select **Multi-Purpose Tray**. Send the job to the printer.

1

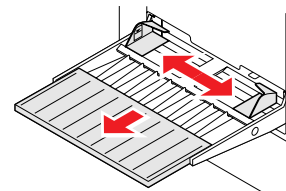

2

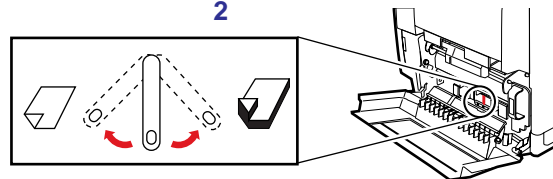

3

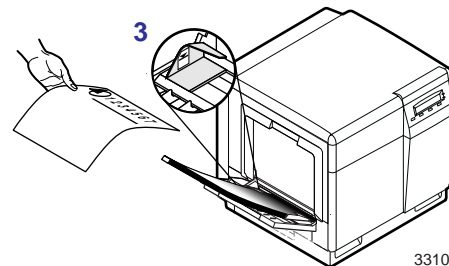

## Setting Media Thickness

Manually select a media thickness for the most reliable paper-picking from the Multi-Purpose Tray.

- 1 Open the left side door. The blue media thickness switch has three settings and is located on the paper feeder.
- 2 Move the switch to the desired setting:

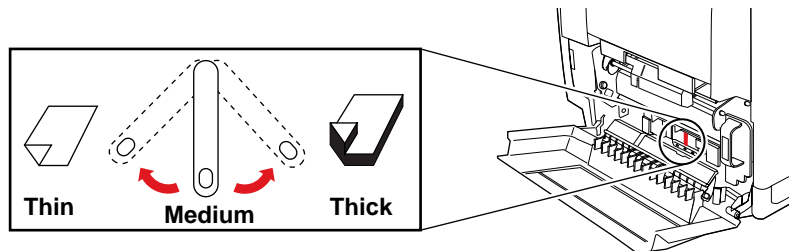

33100-24

### Thin

Standard laser paper 75 - 105 g/m<sup>2</sup>  
(20 - 28 lb.)

### Medium

Heavy laser paper 109 - 150 g/m<sup>2</sup> (29 - 40 lb.)  
Tektronix Glossy Coated paper  
Tektronix transparencies

### Thick

Cover stock up to 163 g/m<sup>2</sup> (60 lb.)  
Card stock up to 163 g/m<sup>2</sup> (40 lb.)  
Index up to 163 g/m<sup>2</sup> (90 lb.)  
Tektronix Fabric Transfer media  
Laser labels  
#10 Envelopes



*For the best coverage when using laser paper heavier than 105 g/m<sup>2</sup> (28 lb.) in the Multi-Purpose Tray, select **Card** as the media type.*

## Loading specialty media

Envelopes

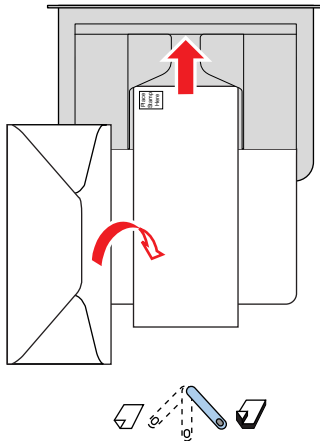

Tektronix Transparencies

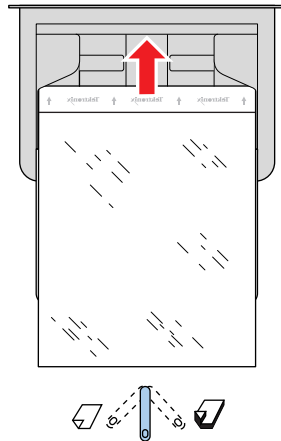

Letterhead

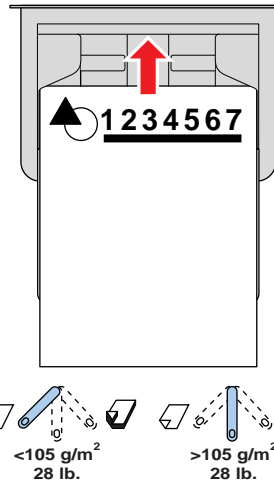

Laser Labels

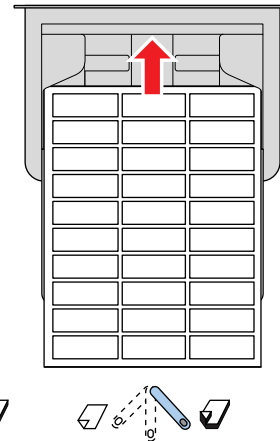

33100-25



*Never use envelopes with windows or metal clasps; they will damage the printer. Use envelopes that are at least #10-size.*



*Never use media for inkjet printers; inkjet media may damage the Fuser. Tektronix laser media are specially designed for this printer.*

### Paper 2nd Side

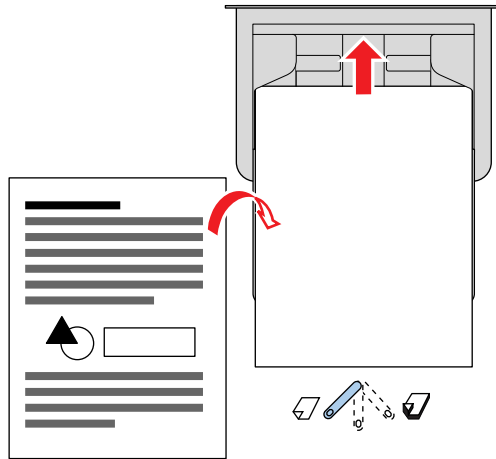

### Tektronix Fabric Transfer

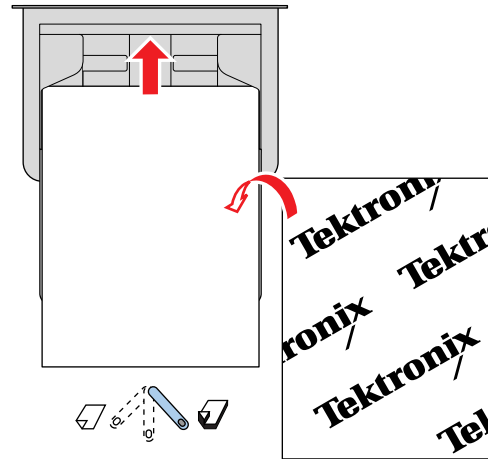

### Tektronix Glossy Coated Paper

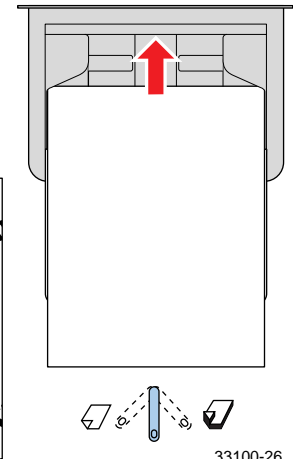

33100-26



For best results on double-sided printing, use 90 g/m<sup>2</sup> (24 lb. bond) laser paper.



Feed Fabric Transfer Media one sheet at a time; otherwise the media may jam.

## Printing Envelopes

- 1 Prepare each envelope: tuck in the envelope flap.
- 2 Adjust the printer's media thickness switch to **Thick**.
- 3 Adjust the printer's media guides for the width of your envelopes.
- 4 Insert the envelopes (maximum capacity is 10-15, depending on thickness):
  - Short end enters **first**.
  - Side to be printed is **face-up**.
  - The edge where you place the stamp enters the printer **first** in some applications; make a test print before proceeding.
- 5 At the front panel prompt, scroll to **Card or Envelope** and press **OK**.
- 6 In the front panel's **Printer Defaults** menu, scroll to **Multi-Purpose Media** and select **#10 Envelope** under **Media Size**.

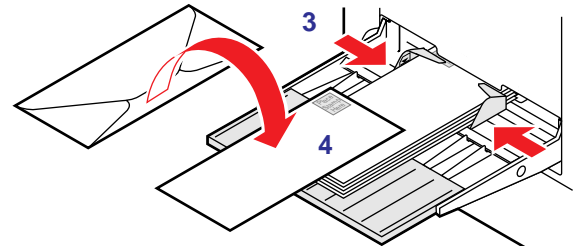
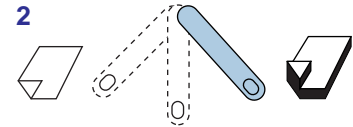
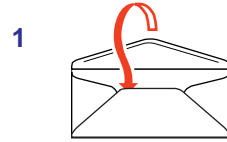

7 In your application:

- Create a document with these measurements:

- Width: 4.13 in. (104.1 mm)
- Length: 9.5 in. (241.3 mm)
- Margins: .2 in. (5 mm)

- Access the **Page Setup** menu and make these selections:

- Paper Size: #10 Envelope
- Orientation: Landscape

8 In the **Print** screen (using a supported printer driver), make this selection and send the job to the printer.

- Paper Source: Multi-Purpose Tray

### Guidelines for envelope printing

- Use envelopes that are at least #10-size (4.13 x 9.5 in. / 104.1 x 241.3 mm).
- No plastic windows or metal clips.
- No exposed gummed surfaces.
- Tuck the gummed flap into the envelope.
- Single-sided printing only.
- Keep unused envelopes in their original packaging.



*This printer is not made to handle high-capacity production envelope printing. Envelopes may wrinkle depending on weight and stiffness of envelope media.*

## Printing on labels

Recommended Avery™ labels:

**A/Letter:** 5160  
5164

**A4:** L7162  
L7165

### At the printer

- 1 Adjust the printer's media thickness switch to **Thick**.
- 2 Insert the label sheets (maximum capacity is **30** sheets):
  - Side to be printed is **face-up**.
  - The top of the sheet enters the printer **first**.
- 3 At the front panel prompt, scroll to **Label** and press **OK**.

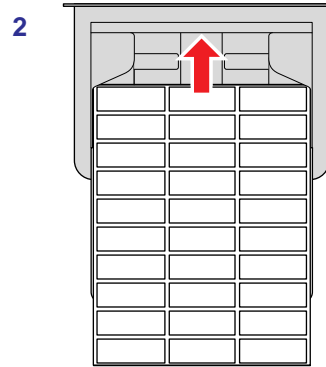
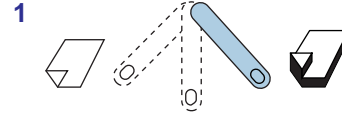

33100-46



## In the application

- 1 If your application has a setting for Avery™ labels, use it as a template. Otherwise, refer to the instructions included with the labels for margin settings.

### Avery labels

- A/Letter: 5160  
5164
- A4: L7162  
L7165

- 2 In the **Print** screen, select the **Multi-Purpose Tray**. Send the job to the printer.

## Guidelines for printing on labels

- Recommended labels: Use Avery labels.
- Each label is at least 25.4 x 66.7 mm (1 x 2.625 in.) in size. Smaller labels may peel off and damage printer components.
- If any of the labels on a sheet are missing, do not use that sheet; it may damage printer components.
- When selecting **Label1** as the media type, the printer requires that room temperature be cooler than 27° C (81° F). If the temperature is above this, the printer reports an error and stops printing.

## Automatic Duplex Printing

 Automatic duplex printing requires that the Lower Tray Assembly be installed.

- 1 Make sure that the Duplex Unit is inserted in the printer's upper (a) slot.

 Never put media in the Duplex Unit; the printer will report a media jam.

- 2 Load 75 - 90 g/m<sup>2</sup> (20 - 24 lb.) paper in the paper tray.

If you are using pre-printed paper, such as letterhead:

- Place the **first side to be printed face-down**.
- Place the top of the page under the paper tray's hooks.

This example shows letterhead paper.



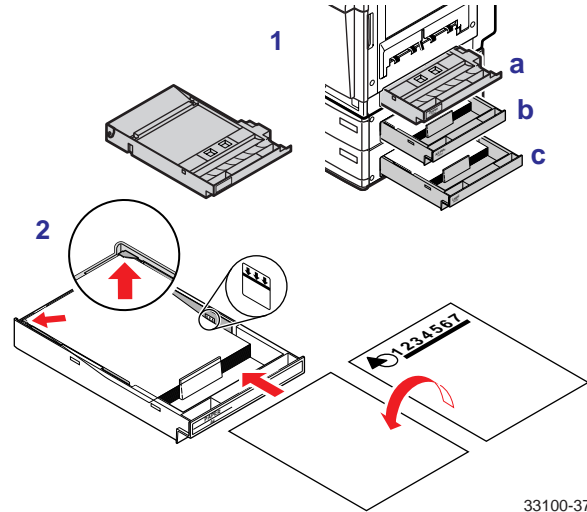

- 3 Insert the paper tray in the printer's middle (b) or lower (c) tray slots.



33100-37

 For best results with duplex printing, use 90 g/m<sup>2</sup> (24 lb.) laser paper.

- 4 Decide on a binding preference (how the page turns) for Step 5:

	Landscape	Portrait
Long edge		
Short edge		

9102-50

- 5 In the **Print** screen, select the **Duplex** option *and* a binding preference:

---

#### Macintosh Drivers:

##### LaserWriter 8.5.1

- From the pull-down menu, choose **Layout**.
- Select **Print on Both Sides**.
- Select a binding preference.



---

##### LaserWriter 8.3.4

- Click **Options**.
- Select **2-Sided Printing**.
- Select **Short-Edge Binding** or **Long-Edge Binding**.

---

#### PC Drivers:

##### Windows 95/ Windows 98

- Click **Properties**.
- Click **Paper**.
- Click **More Options** and select your binding preference.

---

##### Windows NT4

- Click **Properties**.
  - Click **Advanced**.
  - Under **Paper/Output**, select your option for **Print on Both Sides**.
-

## Manual Duplex Printing: Multi-Purpose Tray

### Side 1



For a multi-page document, print **odd-numbered pages for Side 1**. (This selection is application-specific).

- 1 Insert paper with the **side to be printed face-up**. This example shows letterhead paper.
- 2 In the printer's front panel, select the media type at the prompt.

Front panel selection	Media type
Paper:	Standard laser paper 90 - 105 g/m <sup>2</sup> , 24 - 28 lb.
Coated Paper:	Tektronix Glossy Coated paper
Card or Envelope:	Card stock
	Heavy laser paper 109 - 150 g/m <sup>2</sup> , 29 - 40 lb.

- 3 In the **Print** screen (using a supported driver), select **Multi-Purpose Tray** as the Paper Source or Tray Selection. Send the job to the printer.
- 4 Remove the printed paper from the output tray.



Two-sided printing on specialty media can shorten component life.

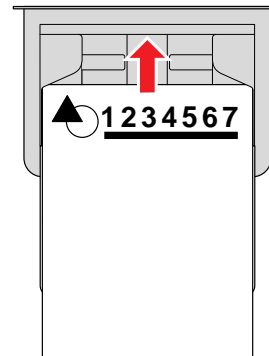

32564-06



For best results with duplex printing, use 90 g/m<sup>2</sup> (24 lb.) laser paper.

## Side 2



For a multi-page document, print **even-numbered pages for Side 2**.  
(This selection is application-specific).

- 1 Insert the paper with the **blank side face-up**.
- 2 In the printer's front panel, select the media type at the prompt.

Front panel selection	Media type
Paper 2nd Side:	Standard laser paper 90 - 105 g/m <sup>2</sup> , 24 - 28 lb.
Coated Paper:	Tektronix Glossy Coated paper
Card or Envelope:	Card stock
	Heavy laser paper 109 - 150 g/m <sup>2</sup> , 29 - 40 lb.

- 3 In the **Print** screen (using a supported driver), select **Multi-Purpose Tray** as the Paper Source or Tray Selection. Send the job to the printer.
- 4 Remove the printed paper from the output tray.

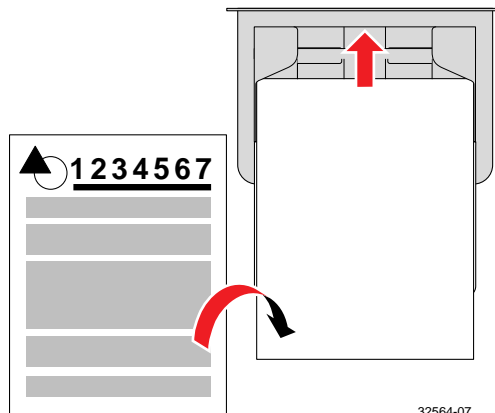

32564-07

# Front Panel Messages

Message	Action	Page
<color>:low	The displayed color Toner Cartridge is running out; replace it soon.	
Energy Star Mode Wake Up            Menu	The printer is in energy conservation mode. Press the <b>Wake Up</b> button on the front panel or send a print job to bring the printer to <b>Ready</b> .	
Error XX	<ol style="list-style-type: none"><li>1 Press the <b>Info</b> button for problem information. Follow any steps listed.</li><li>2 If the failure persists, note the display's error number.</li><li>3 Look up the error number in the online topic "Error Codes" on the printer's CD-ROM or the web site at <a href="http://www2.tek.com/merlin/tko">www2.tek.com/merlin/tko</a>.</li></ol>	
Fuser:replace	Replace the Fuser soon.	
Fuser Roll:replace	Replace the Fuser Roll soon.	
Imaging Unit:replace	Replace the Imaging Unit soon.	
Jam at <Location> Open <door>	A media jam has occurred at the indicated location. The second line of the message indicates the location of the jam.	26
Main Charge Grid:replace	Replace the Main Charge Grid soon.	
Media Tray:empty	Refill the media tray. If your printer has a Lower Tray Assembly, the choices include Upper, Middle, or Lower.	7
MPT:<media type> <--- ---> OK	Media has been loaded in the Multi-Purpose Tray; select that media type in the front panel. Press the arrows to scroll to the appropriate media type; press <b>OK</b> . The printer waits a minute for you to select a media type at the front panel prompt. After a minute, the job prints, using the previously selected media type.	8
Stopped: Fuser Roll:replace	Replace the Fuser Roll <b>now</b> .	
Stopped: replace <color>	The displayed color Toner Cartridge is empty; replace it <b>now</b> .	
Transfer Kit:replace	Replace the Transfer Kit (transfer roller and waste bin) soon.	

## Troubleshooting Print Quality

If you notice a problem with the quality of your prints, the probable solution is replacing one of the consumables. Keep in mind this basic guideline:

- If the symptom appears in a single color:  
**Replace the Toner Cartridge.**
- If the symptom appears in all colors:  
**Replace the Imaging Unit, or Fuser, or Fuser Roll, or Main Charge Grid, or Transfer Kit.**

### To diagnose the problem, check these items:

- 1 Check the front panel for a message on replacing a consumable.
- 2 From the **Help Pages** menu, print the Consumables Page; use it to diagnose and correct problems; it contains useful information, such as the remaining life for consumables.
- 3 From the front panel **Help Pages** menu, print Service Print 1. Examine prints for symptoms.



For detailed troubleshooting information, refer to the **Advanced Features and Troubleshooting Manual** on the printer's CD-ROM or web site.

1

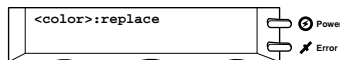

2

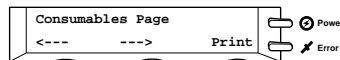

3

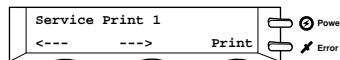

33100-01

**Symptom:** In one color only?

**Solution:** Replace that color Toner Cartridge.

1 color has many vertical streaks.

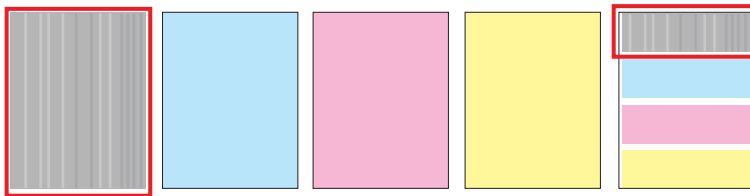

Replace the Toner Cartridge.

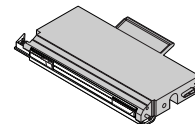

1 color has a light vertical streak.

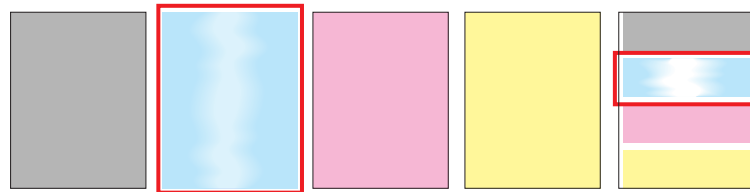

- 1 Adjust the color density (see page 38).
- 2 Replace the Toner Cartridge.

1 color is light or faded.

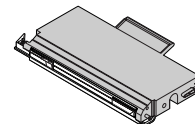
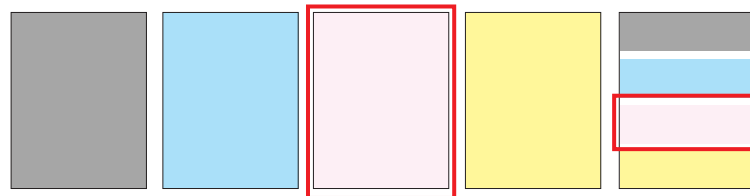



**Symptom:** In all four colors?

**Solution:** 1) Choice of media or 2) Replace Imaging Unit, or Fuser, or Fuser Roll.

Streak through all 4 colors.

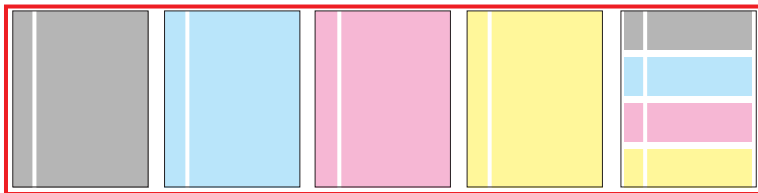

Spot in the same place on the page in all 4 colors.

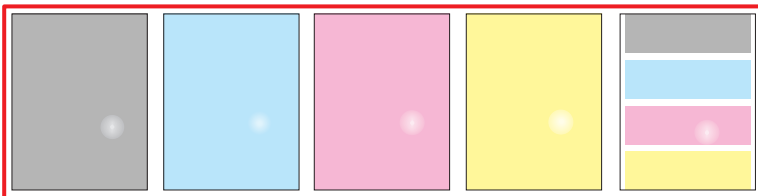

Random spots appear on every page.

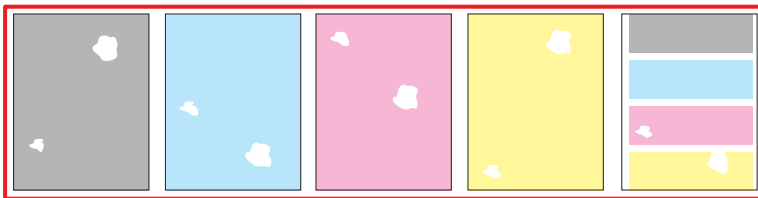

- 1 Use Tektronix media.
- 2 Use the correct media tray for the media you are using.
- 3 When using the Multi-Purpose Tray, select the correct media in the front panel.
- 4 Print about 25 blank pages until the problem disappears.
- 5 Replace the Imaging Unit.

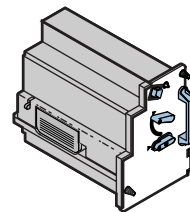

**Symptom:** In all four colors?

**Solution:** 1) Choice of media or  
2) Replace Imaging Unit, or Fuser, or Fuser Roll or Main Charge Grid.

24

Prints are black (edge to edge).



- 1 Remove, then re-insert the Main Charge Grid.
- 2 Replace the Main Charge Grid.

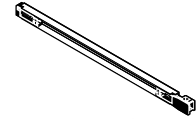

All 4 colors are extremely faded.

**or**

Each page has a chipped corner.

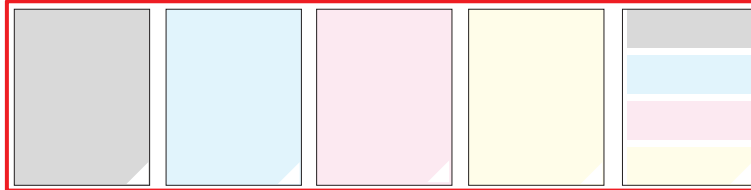

#### Hints

- Use Tektronix media.
- Use the correct media tray for the media you are using.
- When using the Multi-Purpose Tray, select the correct media in the front panel.
- Relative humidity may be too low (below 30% relative humidity).

**Symptom:** In all four colors?

**Solution:** 1) Choice of media or  
2) Replace Imaging Unit, or Fuser, or Fuser Roll or Main Charge Grid.

Pieces of the printed image are missing and reappear out of place, approximately 129 mm (5 in.) down the page.



**or**

Media frequently wraps around the Fuser (**Jam at c**).

#### Hints

- Use Tektronix media.
- Print 10-20 blank pages of **plain** paper.
- To avoid jams with Tektronix transparencies, make sure that the logo strip is loaded **face-down** for the Multi-Purpose Tray and **face-up** for the transparency tray.

If **Jam at c**, clear the media jam.  
Print 10-20 blank pages to clean the roller.

- If you still see the problem, replace the Fuser Roll.

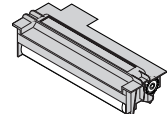

- If you still see the problem, replace the Fuser.

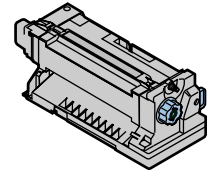

## Media Jams

### Preventing media jams

- To reduce the frequency of media jams, use Tektronix media and occasionally clean the rollers. See page 32.
- When using the Multi-Purpose Tray, always set the media thickness switch for the media you are using. See page 9.
- If the printer frequently reports **Jam at Multi-Purpose**, move the media thickness switch to a thicker setting.

### Locating a jam

The front panel reports **Jam at <Location>**.  
The **<Locations>** are the sensors listed as **A** through **E**.  
Line 2 of the front panel message directs you to the location of the jam. For example:

Jam at A  
Open left side door

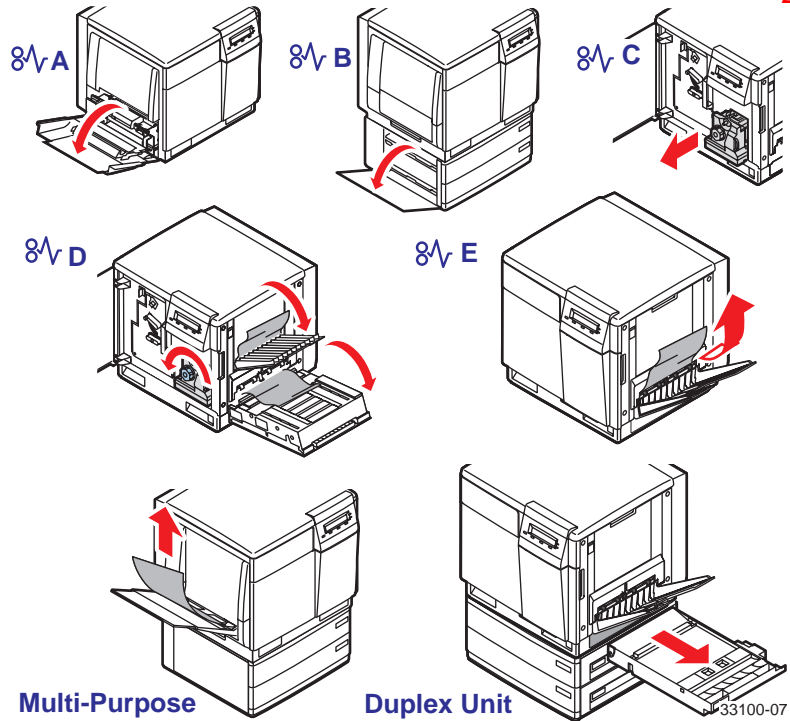

## Jam at A

### Solution 1

Open the left side door;  
remove the jammed media.

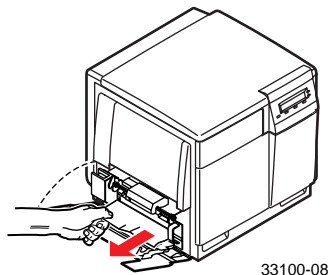

### Solution 2

Remove the media tray;  
remove the jammed media  
from inside the printer.

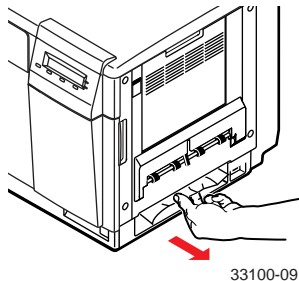

## Jam at B

### Solution 1

Open the lower left side door  
and remove the jammed  
media.

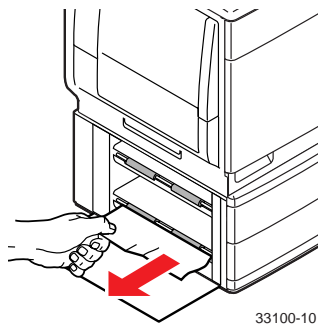

### Solution 2

Remove the selected media  
tray (middle or lower tray)  
and remove the jammed media  
from inside the printer.

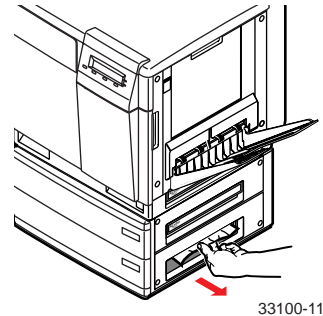

## Jam at C

- 1 Remove the Fuser:
  - a Open the printer's front door.
  - b Turn the small blue thumbscrew *counterclockwise* to unlock the Fuser.
  - c Press the safety catch and slide the Fuser out of the printer.
- 2 Remove the Fuser Roll:
  - a Press *out* on the two tabs to unlock the Fuser Roll.
  - b Lift the Fuser Roll out of the Fuser and set it aside.
- 3 Turn the Fuser's large blue knob *clockwise* or *counterclockwise* to release the jammed media.
- 4 Remove the jammed media from the Fuser.
- 5 Re-insert the Fuser Roll into the Fuser; re-install the Fuser.



The Fuser is hot. To avoid personal injury, use caution or wait for it to cool before touching it.

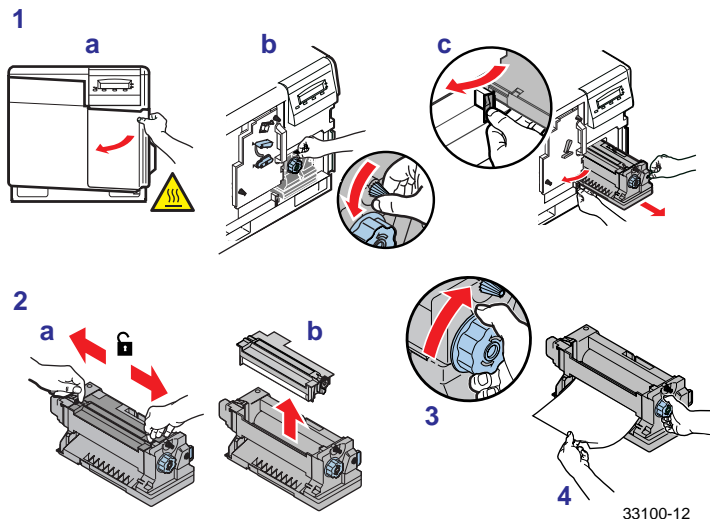

## Jam at D

### Solution 1

- 1 Open the front door.
- 2 Pull open the access door; the media is visible.
- 3 Turn the Fuser's large blue knob *counterclockwise*.
- 4 Remove the media.

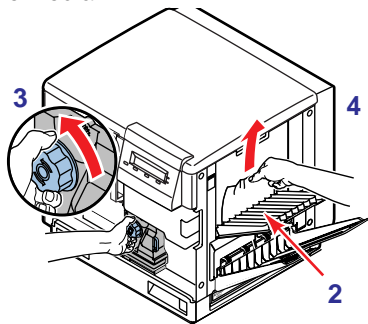

33100-13



If the Fuser knob will not turn, do not force it or you may damage the Fuser. Instead, remove the Fuser and Fuser Roll; then turn the Fuser knob to release the jammed media.



The Fuser is hot. To avoid personal injury, use caution or wait for it to cool before touching it.

### Solution 2

- 1 Open the front door **and** the right side door.
- 2 Turn the Fuser's large blue knob *counterclockwise*.
- 3 Remove the jammed media.

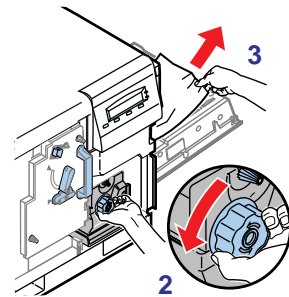
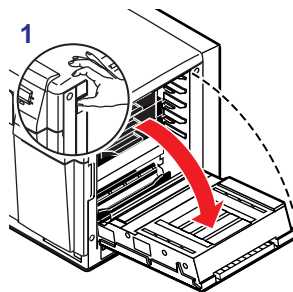

33100-14

## Jam at E

### Solution 1

Remove the jammed media from the output tray.

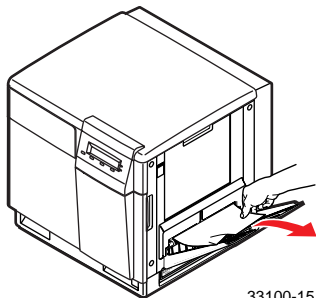

33100-15

### Solution 2

Pull open the access door (above the plastic output tray) and remove the media.

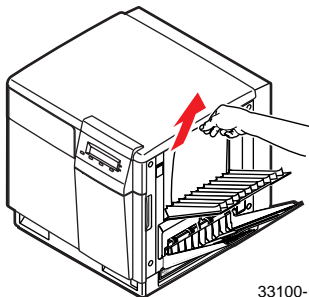

33100-16



Open and close the printer's front door to clear the error message.

## Jam at Multi-Purpose Tray

30

- 1 Remove all media in the Multi-Purpose Tray.
- 2 Remove the jammed media from the Multi-Purpose Tray.
- 3 Set the Media Thickness switch for the media you are using (page 9).
- 4 Re-insert the media in the Multi-Purpose Tray.

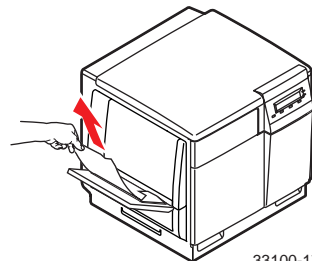

33100-17



Open and close the printer's front door to clear the error message.



## Jam at Duplex Unit

- 1 Remove the Duplex Unit (it is in the printer's **upper** slot).
- 2 Open the Duplex Unit.
- 3 Remove the jammed media.

 *If paper is not in the Duplex Unit, open the right side door; paper may be jammed there.*

- 4 Close the Duplex Unit; press down to make sure that it snaps shut.
- 5 Re-insert the Duplex Unit into the printer's **upper** slot.

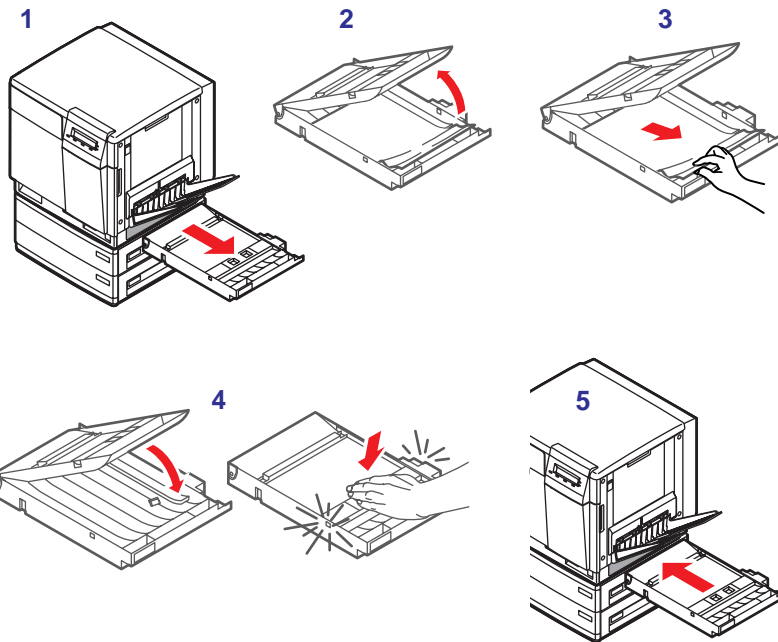

33100-18

## Occasional Cleaning

If your printer experiences frequent media jams, clean the rollers. Instructions are included in these locations:

- **Cleaning** menu in the front panel
- Video clips on the printer's CD-ROM

### Print the cleaning instructions

- 1 On the printer's front panel, press **Menu**.
- 2 Press the arrow buttons; scroll to **Cleaning**. Press **Menu**; this message displays:

```
Print instructions
<---   --->   Print
```

- 3 Press **Print**.
- 4 Follow the instructions on the cleaning page.

## Replacement cleaning kit 016-1710-00

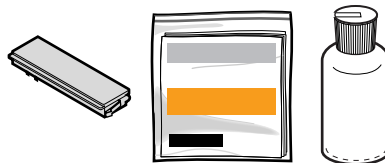

33100-49

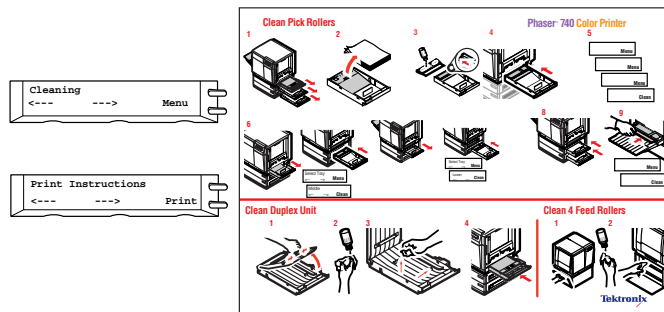

33100-65



*Use isopropyl alcohol (at least 90% pure) with a lint-free cloth. Do not use alcohol that has any additives; it can damage the printer.*

## Printing Help Pages from the Front Panel

The front panel contains pages to help you use the printer and diagnose print quality.

- 1 On the printer's front panel, press **Menu**; you see this message:

```
Help Pages
<---  ---> Menu
```

- 2 Press **Menu**; you see this message:

```
Consumables Page
<---  ---> Print
```

- 3 Press <--- or ---> to scroll to any of these help pages:

```
Consumables Page (1)
Configuration Page (2)
Startup Page
Usage Profile (3)
Demonstration Page
Service Print 1 and 2 (4)
RGB Sampler Prints
CMYK Sampler Prints
Menu Map (5)
```

- 4 Press **Print**.

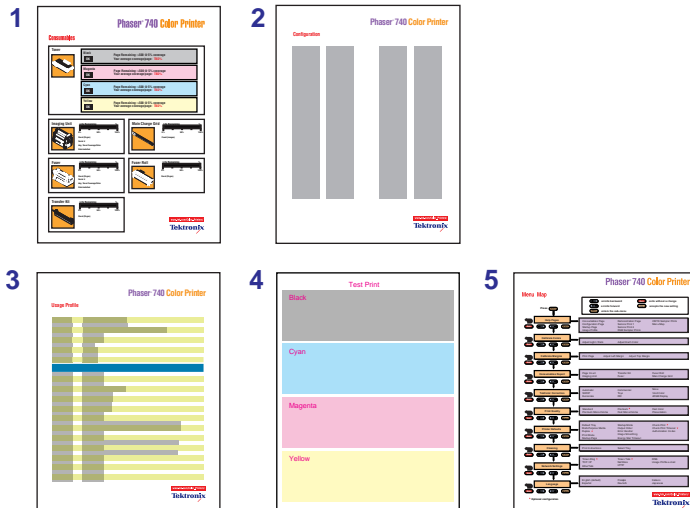

33100-66



Print the menu map from the front panel; keep it by the printer for easy reference.

# Consumables Information

## Using the Consumables Page

- **Toner life remaining:**

**OK** More than 500 pages remaining at 5% coverage

**LOW** Less than 500 pages remaining at 5% coverage

- **% Remaining** gauge for all other consumables

- **Count**

- **Average Toner Coverage per Color**

- **Date of installation**

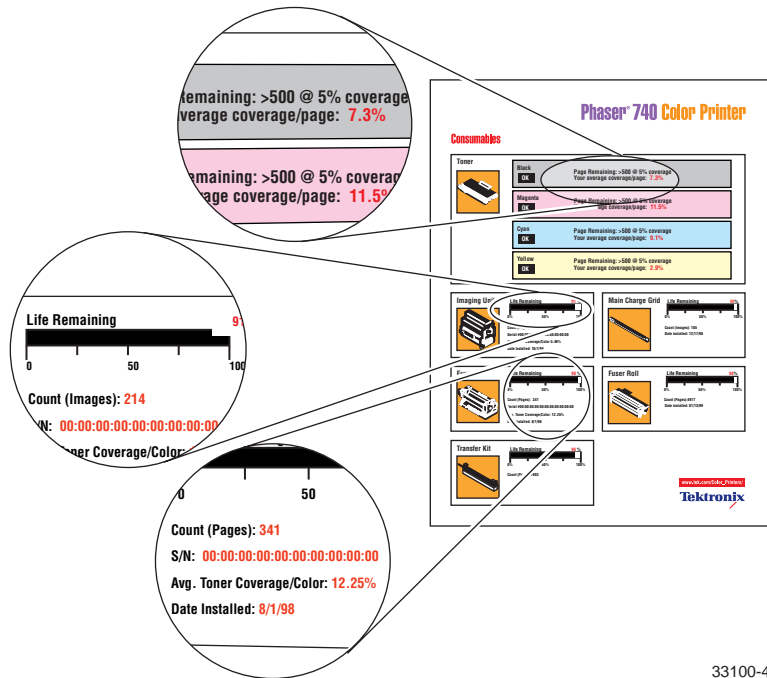

## Using the Usage Profile Report

Provides in-depth information on printer usage:

- Consumables used
- Tray and media selections
- Printer interventions
- Analysis of usage rates

For detailed information on the Usage Profile report, refer to “Printer Management” on the printer’s CD-ROM or web site.

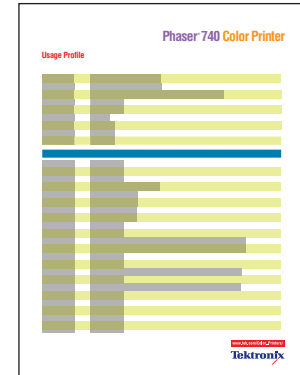

## Using PhaserLink™ software

PhaserLink software, using World Wide Web technology, provides these printer management tools:

- Print job status
- Printer usage
- Routine troubleshooting
- Configuration of printer settings

PhaserLink requires a TCP/IP connection. To access PhaserLink information, enter your printer's Internet address in a web browser.

For detailed information on PhaserLink, refer to "Printer Management" on the printer's CD-ROM or web site. Or enter this address in your web browser:

[www.tek.com/Color\\_Printers/products/phaserlink.html](http://www.tek.com/Color_Printers/products/phaserlink.html)



## Replacing Consumables

Detailed, illustrated replacement instructions are shipped with each replaceable component.

### Component

### Average Life\*

#### Toner

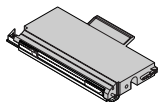

#### Hi-capacity cartridges

10,000 pages (CMY)  
12,000 pages (Black)

#### Standard cartridges

5,000 pages (CMY)  
6,000 pages (Black)

#### Imaging Unit

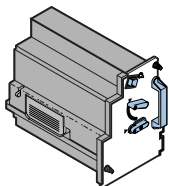

60,000 images

or

15,000 color pages

or

60,000 monochrome pages

#### Transfer Roller

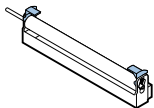

80,000 pages

### Component

### Average Life\*

#### Fuser Roll

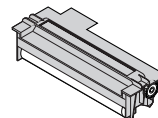

15,000 pages

#### Fuser

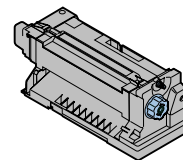

60,000 pages

#### Main Charge Grid



30,000 images

\* Based on an average of 5% coverage of the printable area (at 600 dpi) for any one color on laser paper. The replacement frequency varies with the complexity of the prints, the percentage of coverage, and media type. Printing on specialty media may reduce consumable life. Refer to "User-replaceable components" on the printer's CD-ROM or web site for more details.

## Controlling Color Density

When colors look faded, adjust the toner color density to extend the life of the components.

### Print and use the Color Reference Page

- 1 In the printer's front panel, scroll to **Calibrate Colors**, press **Menu** and print the Color Reference Page.
- 2 Compare the Color Reference Page to the Color Density Samples on page 39. Make a note of the value (-10 to +10) for each color that most closely matches the samples.
- 3 Adjust the density for each color: Enter the value noted in Step 2 in the **Calibrate Colors** menu, under **Adjust Each Color**.
  - *Decrease color density:* Press <---.
  - *Increase color density:* Press --->.
- 4 Reprint the Color Reference Page; check your adjustments.

1

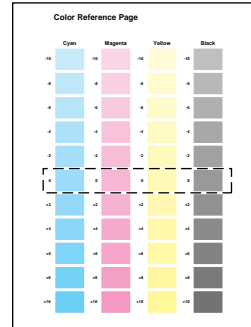

2

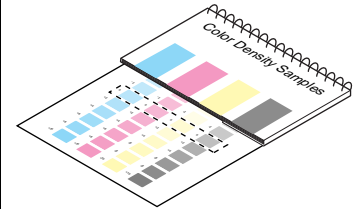

3

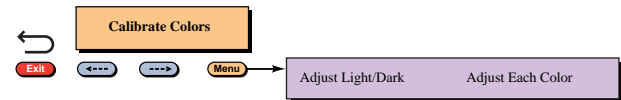



# Color Density Samples

Phaser® 740 Color Laser Printer

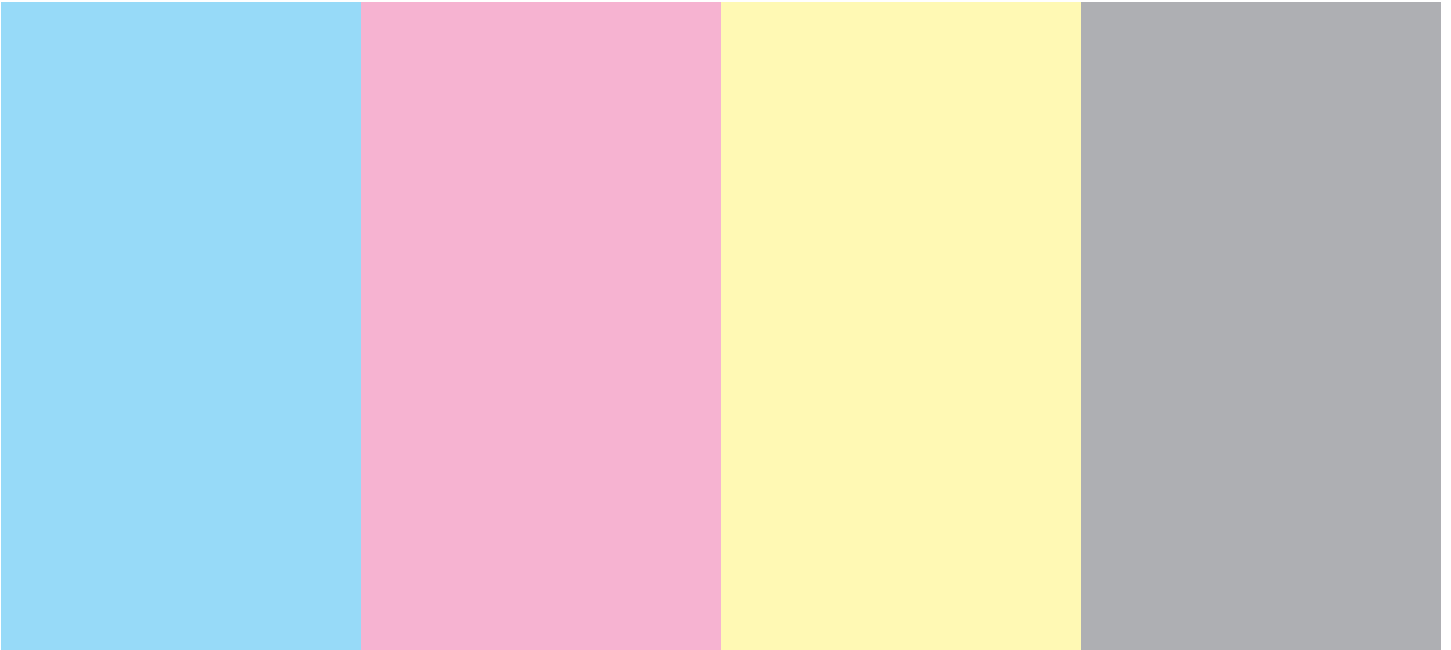



## Getting More Information

Find detailed printer information in any of these locations.

### Printer CD-ROM

- Advanced Features and Troubleshooting
- Consumables instructions
- Cleaning instructions
- Setup Guide
- Network manuals
- Repacking instructions
- Printer drivers
- Material Safety Data Sheets (MSDS)
- Direct link to World Wide Web



### Tektronix Web Site

- Product and supplies information
- Downloading printer drivers
- Finding your local dealer
- Online documentation

[www.tek.com/Color\\_Printers](http://www.tek.com/Color_Printers)



### TekSMART™ Knowledge Base

- Application issues
- Networking issues
- Printer errors
- Print quality issues
- Troubleshooting
- Latest tips from technical support

[www2.tek.com/merlin/tko](http://www2.tek.com/merlin/tko)



### Online Color Resource

- Step-by-step lessons
- Using clip art
- Articles and product reviews
- Tips and techniques
- Templates and tools
- Questions and answers

[www.colorize.com](http://www.colorize.com)



# Getting Help

## Online Services

- World Wide Web:** [www.tek.com/Color\\_Printers/](http://www.tek.com/Color_Printers/)  
**TekSMART™**  
**Knowledge Base:** [www2.tek.com/merlin/tko](http://www2.tek.com/merlin/tko)  
**Technical support:** [www.tek.com/Color\\_Printers/support/colcare.html](http://www.tek.com/Color_Printers/support/colcare.html)  
**Current software:** [www.tek.com/Color\\_Printers/support/software.html](http://www.tek.com/Color_Printers/support/software.html)  
**Anonymous ftp server:** [ftp.tek.com/Color\\_Printers](ftp://ftp.tek.com/Color_Printers)  
**Subscribe to email update notices:** [www.tek.com/Color\\_Printers/support/subscribe.html](http://www.tek.com/Color_Printers/support/subscribe.html)

## Supplies

Information on local Tektronix dealers:

[www.tek.com/Color\\_Printers/contacts](http://www.tek.com/Color_Printers/contacts)

**U. S.**  
1-800-835-6100

**Canada**  
1-800-563-1289

**Outside U.S. and Canada**  
Contact your local Tektronix office for a list of local resellers

## Customer Support Centers

**Australia**  
1-800-811-177

**Austria**  
0660 5804

**Belgium**  
02 720 9602

**Brazil**  
0800 16 0220

**Canada**  
1-800-835-6100

**China**  
10-6235-1230

**Denmark**  
(44) 533 444

**Eastern Europe and the Middle East**  
+44 1908 68187

**Finland**  
0203 206 30

**France**  
01 69 86 8137

**Germany**  
0180 525 3535

**Hong Kong**  
2585-6655

**India (South Asia)**  
(91) 80-227-5577

**Italy**  
02 45 287 000

**Japan**  
81 3 3448 4872

**Korea**  
2-528-5299

**Luxembourg**  
400 847

**Netherlands**  
(040) 267 0440

**New Zealand**  
+61 2 9888 0100

**Norway**  
(22) 723 801

**Singapore (ASEAN)**  
1-800-356-5565

**Spain**  
902 239 272

**Sweden**  
(08) 299 071

**Switzerland**  
155 9493

**Taiwan**  
(02) 2757-1571

**Thailand**  
2-645-4407

**U.K.**  
(01) 908 681 707

**U.S.**  
1-800-835-6100